

THIS DRAWING CONTAINS PROPRIETARY INFORMATION AND MAY NOT BE ISSUED OR REPRODUCED, IN WHOLE OR IN PART, WITHOUT EXPRESS WRITTEN PERMISSION OF PLASTICS ONE INC

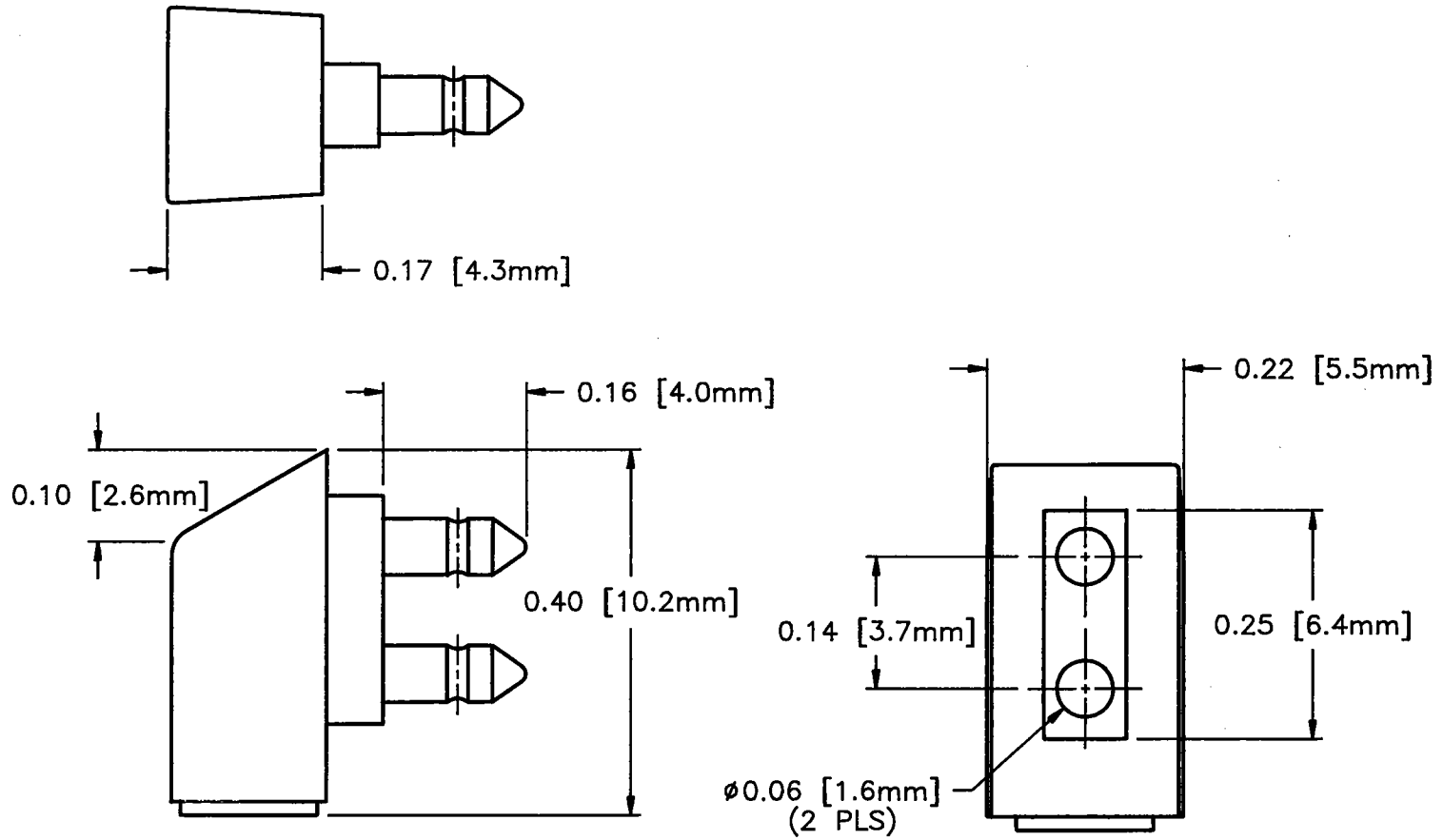

TOLERANCES UNLESS OTHERWISE SPECIFIED ALL DIMENSIONS IN INCHES DIMENSIONS IN [] METRIC		APPROVALS DRAWN W.D.S.	DATE 3/10/83	 6591 MERRIMAN ROAD, S.W., ROANOKE, VA, 24018 PHONE: 703-772-7950 FAX: 703-989-7915	
FRACTIONAL $\pm 1/64$		CHECKED	PROJ ENGR		
DECIMAL $.00 \pm .01$ [.25mm] $.000 \pm .005$ [.127mm]		APPROVED LL	1/20/94	ICN	SCALE 5-1
ANGULAR $\pm .5^\circ$		PROJECT	FSCM	SIZE DWG A 2032-50	REV A SHT 1 OF 1

A	REV PER ECO 324 6/19/93 WSC	1/20/94	LL
REV.	DESCRIPTION	DATE	BY

THIS DRAWING CONTAINS PROPRIETARY INFORMATION AND MAY NOT BE ISSUED OR REPRODUCED, IN WHOLE OR IN PART, WITHOUT EXPRESS WRITTEN PERMISSION OF PLASTICS ONE INC