

THIS DRAWING CONTAINS PROPRIETARY INFORMATION AND MAY NOT BE ISSUED OR REPRODUCED, IN WHOLE OR IN PART, WITHOUT EXPRESS WRITTEN PERMISSION OF PLASTICS ONE INC

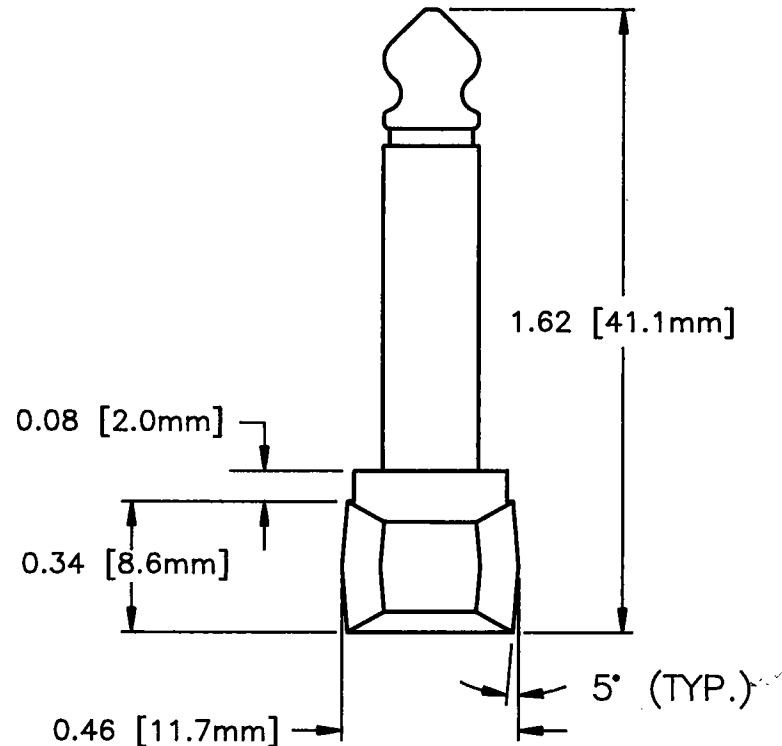
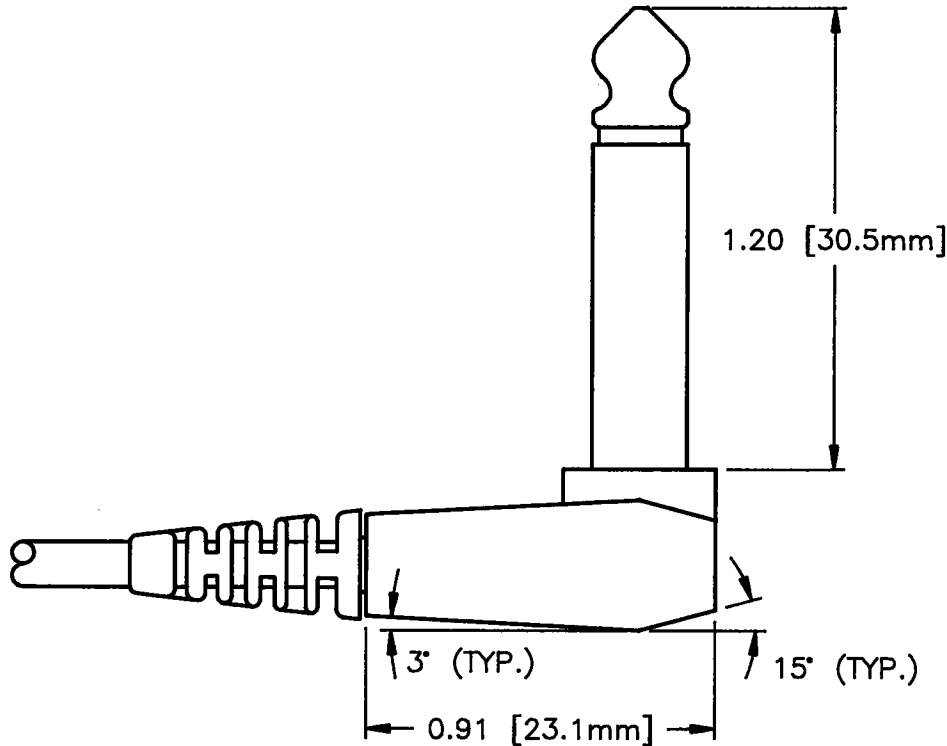

| | | | |
|--|---|------------------------|--|
| TOLERANCES UNLESS OTHERWISE SPECIFIED ALL DIMENSIONS IN INCHES DIMENSIONS IN [] METRIC | APPROVALS DRAWN K. EPPERLY | DATE 3-14-88 | HOLDING THE FUTURE INC 6591 MERRIMAN ROAD, S.W., ROANOKE, VA, 24018 PHONE: 703-772-7950 FAX: 703-989-7519 |
| | CHECKED | | |
| FRACTIONAL $\pm 1/64$ | PROJ ENGR | | TITLE PLUG, 218 |
| DECIMAL $.00 \pm .01$ [.25mm] $.000 \pm .005$ [.127mm] | APPROVED | 12-9-93 | ICN SCALE 2-1 |
| ANGULAR $\pm .5^\circ$ | PROJECT | FSCM | SIZE DWG A 2327-50 |
| THIS DRAWING CONTAINS PROPRIETARY INFORMATION AND MAY NOT BE ISSUED OR REPRODUCED, IN WHOLE OR IN PART, WITHOUT EXPRESS WRITTEN PERMISSION OF PLASTICS ONE INC | | | REV A |
| | | | SHT 1 OF 1 |

| | | | |
|---|---------------------------------|---------|--|
| A | TO ACAD PER ECO 450 4/12/94 WSB | 12-9-93 | |
|---|---------------------------------|---------|--|

| REV. | DESCRIPTION | APPROVAL DATE | APPROVED BY |
|------|-------------|---------------|-------------|
|------|-------------|---------------|-------------|