

4

3

2

1

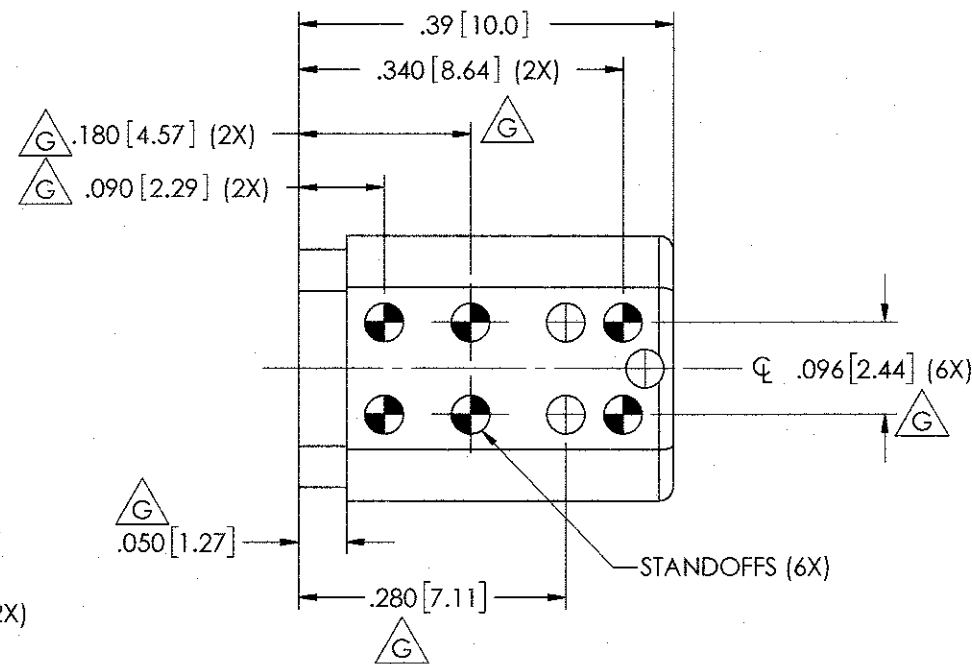
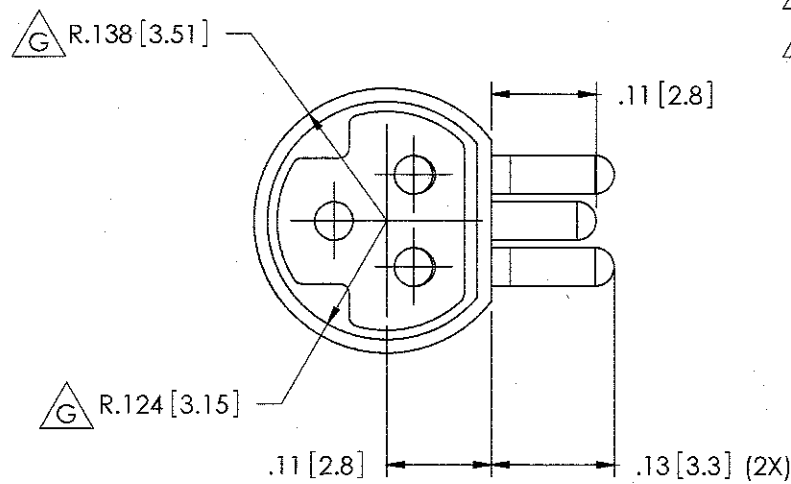
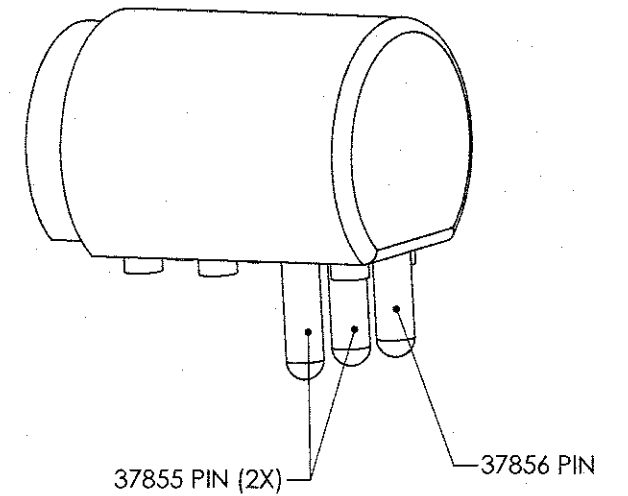
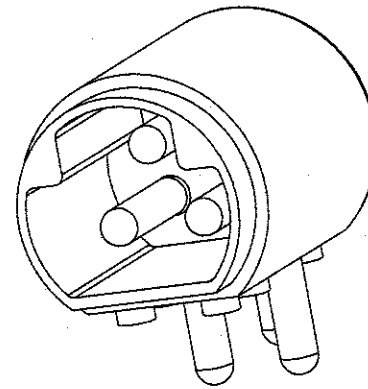
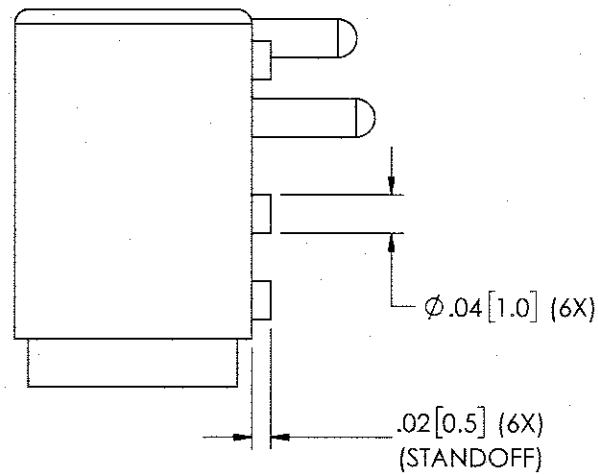

NOTES:

1. MATERIAL: PBT  
OTHER MATERIALS AVAILABLE
2. SIGNAL CONTACT PLATING: SOFT NICKEL, THEN SOFT GOLD
3. PIN SETBACK: 0.07" [1.8 MM]  
EN 60601 TOUCHPROOF
4. GENERAL PERFORMANCE (CONTACT POI FOR TEST CONDITIONS)  
EXTRACTION FORCE: 1.1 LBS MINIMUM (4.9N)  
LIFE CYCLE: 1000+ INSERTION CYCLES  
HIPOT: 1000 VAC between contacts  
5000 VDC TO ANY EXPOSED METAL COMPONENTS  
MAX. CURRENT: 8 AMPS
5. OPERATING TEMPERATURE: +5° C to + 60° C
6. UL94 V-0/5V
7. WAVE SOLDERABLE
8. MATES WITH 44-SERIES & 444 PLUGS

JDN

| REV.      | DESCRIPTION                    | DATE     | APPROVED |
|-----------|--------------------------------|----------|----------|
| G         | REV PER ECO 28666 XZ 2/17/17   | 3/28/17  | SJA      |
| F         | REV PER ECO 28049 TAS 10/24/16 | 10/27/16 | TAS      |
| E         | REV PER ECO 8484 GSX 1/26/05   | 3/30/05  | GS       |
| D         | REV PER ECO 7355 GS 5/17/04    | 6/9/04   | GS       |
| C         | REV PER ECO 3358 SJ 2/13/98    | 5/6/98   | SJ       |
| B         | REV PER ECO 3233 SJ 12/15/97   | 12/17/97 | SJ       |
| A         | REL PER ECO 3019 SJ 9/3/97     | 9/3/97   | SJ       |
| REVISIONS |                                |          |          |

| TOLERANCES   |  | APPROVALS                      | DATE    |
|--|--|--------------------------------|---------|
| UNLESS OTHERWISE SPECIFIED<br>ALL DIMENSIONS IN INCHES<br>DIMENSIONS IN [ ] METRIC |  | DRAWN<br>JAMISON               | 6/16/97 |
| FRACTIONAL<br>±1/64  |  | CHECKED<br><i>[Signature]</i>  | 3/27/17 |
| DECIMAL<br>.00 ±.01 [.25mm]<br>.000 ±.005 [.127mm]                                 |  | PROJ ENGR                      |         |
| ANGULAR<br>±.5°  |  | APPROVED<br><i>[Signature]</i> | 3/27/17 |
|  |  | PROJECT<br>6731-05             | FSCM    |

# PlasticsOne

Medical, Research & Audio Components  
6591 MERRIMAN ROAD, S.W., ROANOKE, VA, 24018  
PHONE: 540-772-7950 FAX: 540-989-7519

TITLE JACK, 3 PIN, .040 TRIANGULAR  
6 STANDOFFS .020 TALL

SCALE 5:1

|                  |                 |          |               |
|------------------|-----------------|----------|---------------|
| SIZE<br><b>B</b> | DWG<br>37817-50 | REV<br>G | SHT<br>1 OF 1 |
|------------------|-----------------|----------|---------------|

THIS DRAWING CONTAINS CONFIDENTIAL AND PROPRIETARY INFORMATION AND MAY NOT BE ISSUED OR REPRODUCED, IN WHOLE, OR IN PART, WITHOUT THE EXPRESS WRITTEN PERMISSION OF PLASTICS ONE INC.