

SCALE 1/1

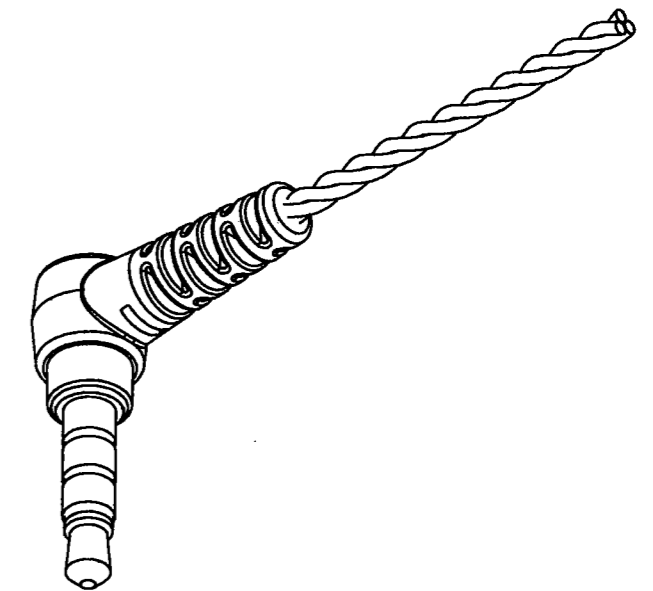
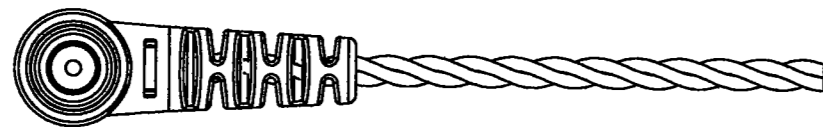
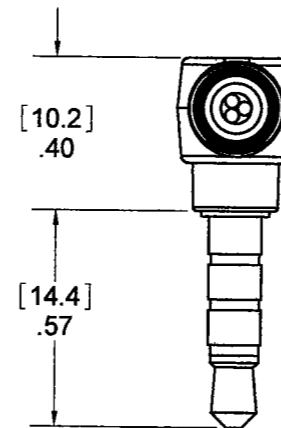
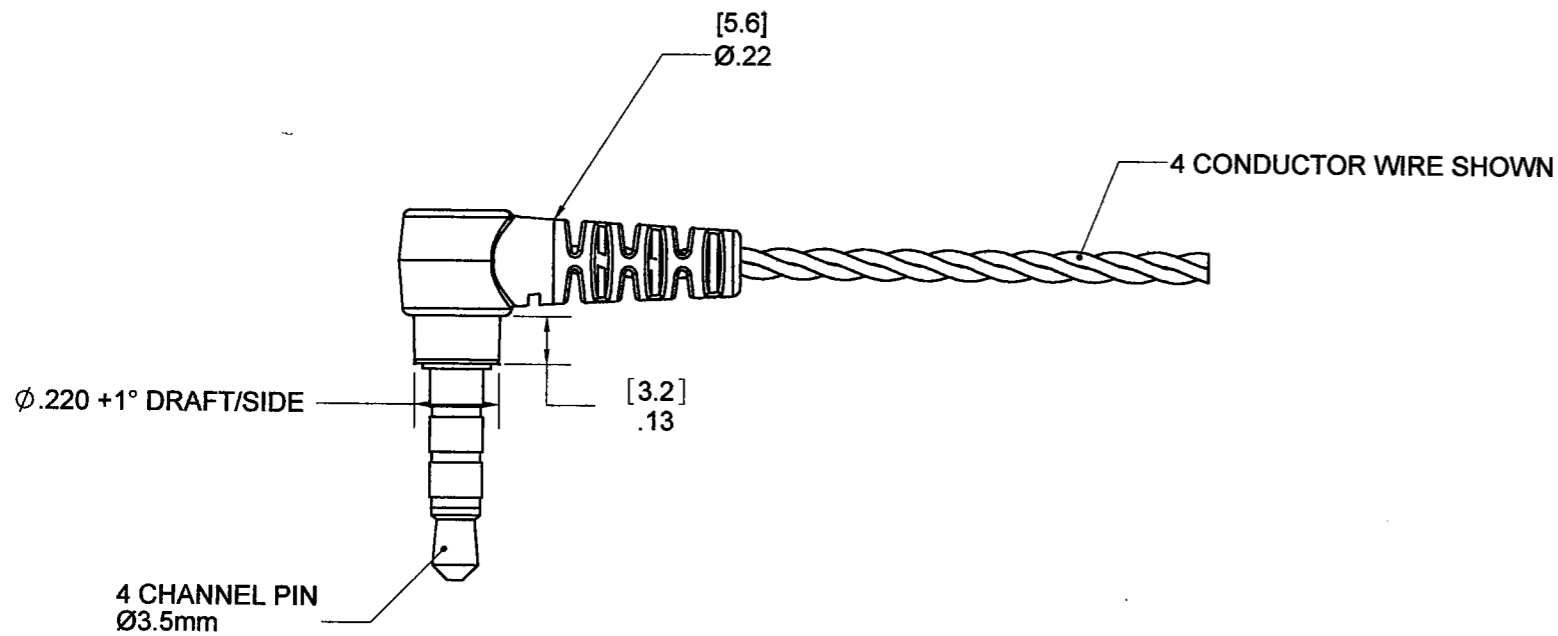
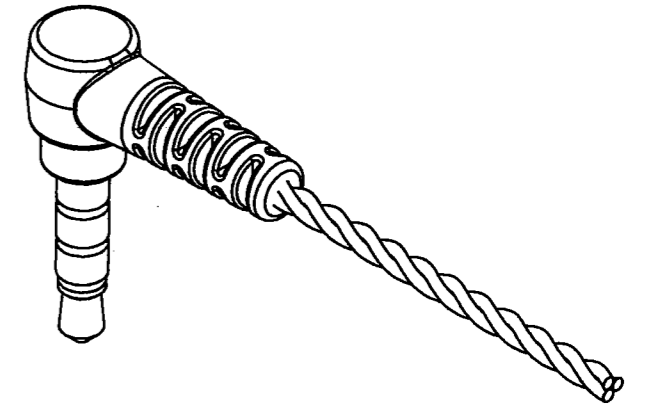

THIS DRAWING CONTAINS CONFIDENTIAL AND PROPRIETARY INFORMATION AND MAY NOT BE ISSUED OR REPRODUCED, IN WHOLE, OR IN PART, WITHOUT THE EXPRESS WRITTEN PERMISSION OF PLASTICS ONE INC.

REV.	DESCRIPTION	APPROVAL DATE	APPROVED BY
C	REV PER ECO 11246 JAP 5/15/2008	5-21-08	JAP
B	REV PER ECO 11113 JAP 3/4/2008	3/5/08	JAP
A	REL PER ECO 11104 JAP 2/21/2008	2/27/08	JAP

TOLERANCES UNLESS OTHERWISE SPECIFIED ALL DIMENSIONS IN INCHES DIMENSIONS IN [ ] METRIC		APPROVALS	DATE	<b>Plastics ONE</b> <sup>®</sup> MOLDING THE MEDICAL FUTURE 6591 MERRIMAN ROAD, S.W., ROANOKE, VA, 24018 PHONE: 540-772-7950 FAX: 540-989-7519
FRACTIONAL ±1/64	DECIMAL .00 ±.01 [.25mm] .000 ±.005 [.127mm]	DRAWN J PARKER	2/21/08	
ANGULAR ±.5°		CHECKED <i>[Signature]</i>	5/15/08	
		PROJ ENGR		
		APPROVED <i>[Signature]</i>	5/15/08	
		PROJECT 7535	FSCM	
		TITLE PLUG,569, 3.5mm 4 POLE RIGHT ANGLE		
		SCALE	NOTED	
SIZE	DWG	REV	SHT OF	
B	40069-50	C	1 OF 1	