

4

3

2

1

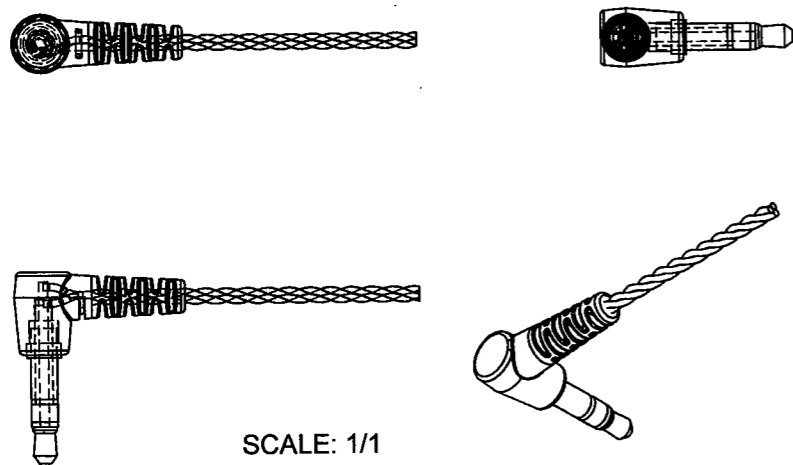

SCALE: 1/1

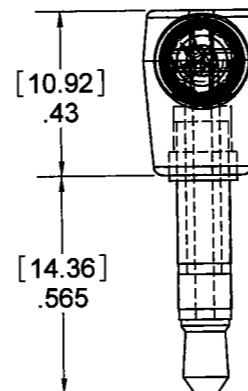
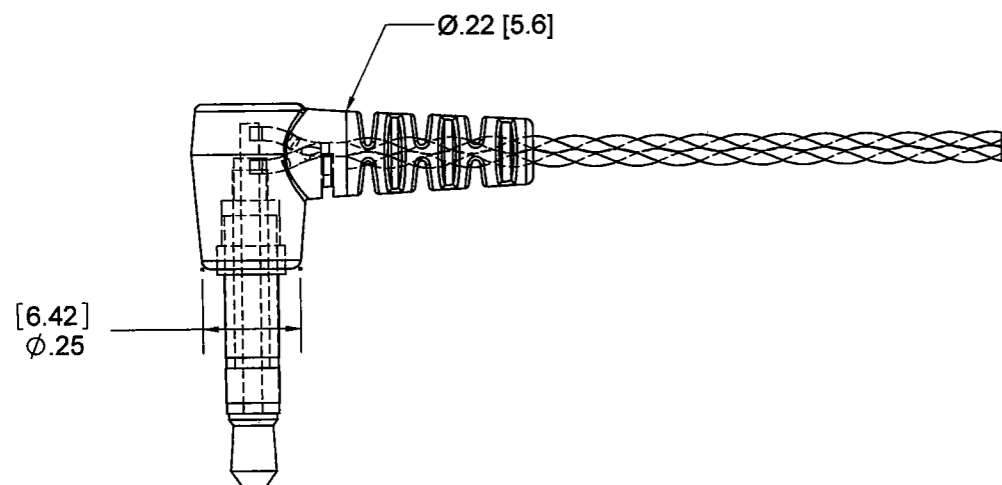
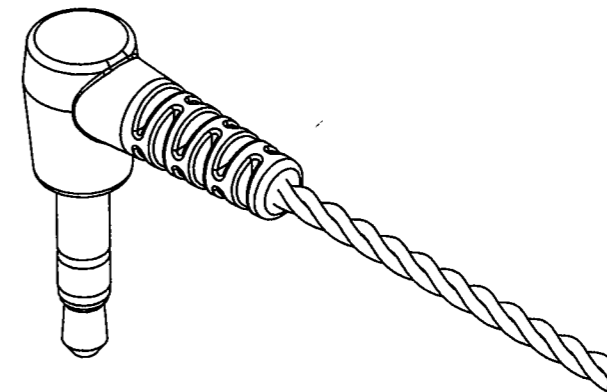

SCALE: 2/1

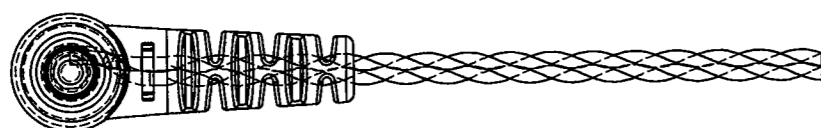
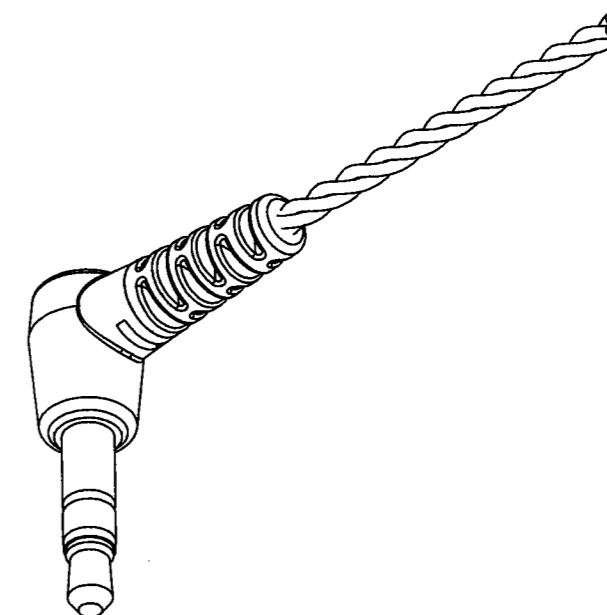

THIS DRAWING CONTAINS CONFIDENTIAL AND PROPRIETARY INFORMATION AND MAY NOT BE ISSUED OR REPRODUCED, IN WHOLE, OR IN PART, WITHOUT THE EXPRESS WRITTEN PERMISSION OF PLASTICS ONE INC.

REV.	DESCRIPTION	APPROVAL DATE	APPROVED BY
A	REL PER ECO 11799 JAP 3/5/2009	18 Mar 09	TMK

<b>TOLERANCES</b> UNLESS OTHERWISE SPECIFIED ALL DIMENSIONS IN INCHES DIMENSIONS IN [ ] METRIC		<b>APPROVALS</b> DRAWN J PARKER CHECKED [Signature] 3/11/09 PROJ ENGR APPROVED [Signature] 3/13/09 PROJECT 7535	<b>DATE</b> 3/5/09	<b>PlasticsOne</b> <b>Medical Design and Manufacture</b> 6591 MERRIMAN ROAD, S.W., ROANOKE, VA, 24018 PHONE: 540-772-7950 FAX: 540-989-7519
<b>FRACTIONAL</b> $\pm 1/64$ <b>DECIMAL</b> .00 $\pm 0.01$ [.25mm] .000 $\pm 0.005$ [.127mm] <b>ANGULAR</b> $\pm .5^\circ$	<b>TITLE</b> PLUG, 584, 3.5mm STEREO, RIGHT ANGLE	<b>SCALE</b> B	<b>NOTED</b> REV A SHT 1 OF 1	