

SCALE: 1/1

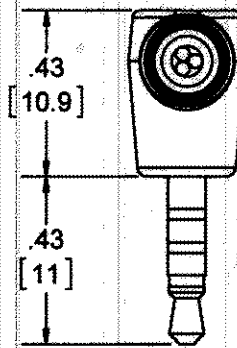

SCALE: 2/1

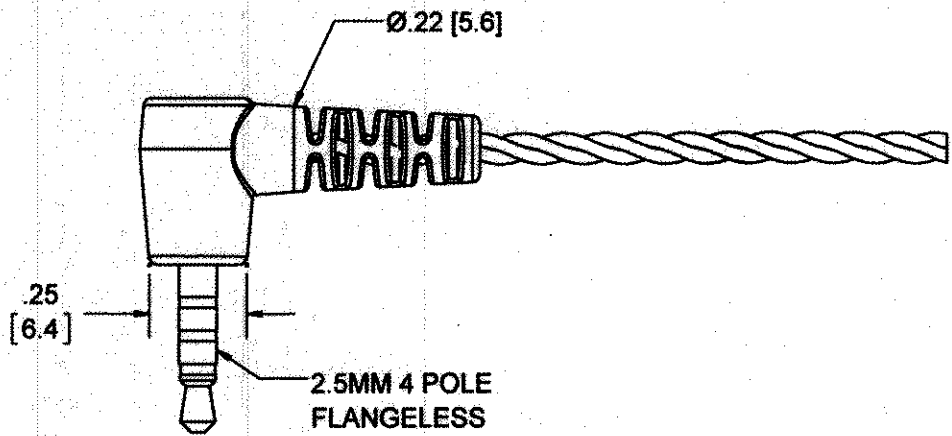
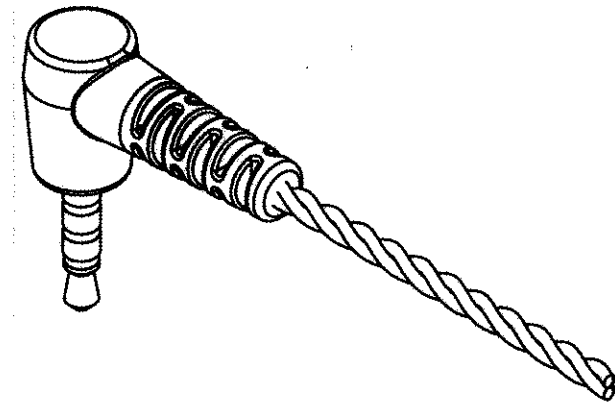
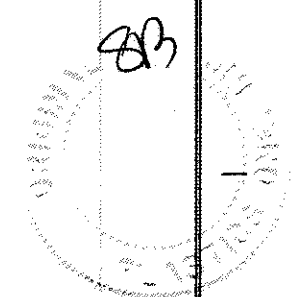
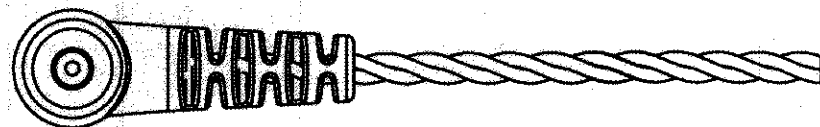
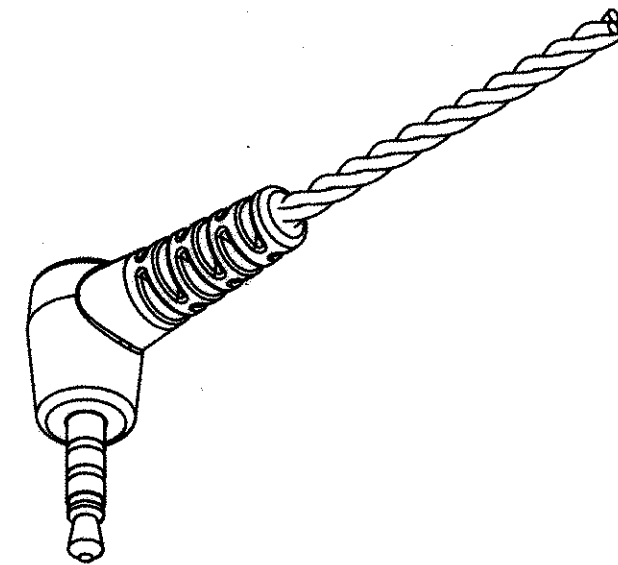

THIS DRAWING CONTAINS CONFIDENTIAL AND PROPRIETARY INFORMATION AND MAY NOT BE ISSUED OR REPRODUCED, IN WHOLE, OR IN PART, WITHOUT THE EXPRESS WRITTEN PERMISSION OF PLASTICS ONE INC.

REV.	DESCRIPTION	APPROVAL DATE	APPROVED BY
A	RELEASE PER ECO 24492 TAS 4/2/15	4/17/15	COG

TOLERANCES UNLESS OTHERWISE SPECIFIED ALL DIMENSIONS IN INCHES DIMENSIONS IN [] METRIC		APPROVALS DRAWN T. STUMP CHECKED PROJ ENGR APPROVED PROJECT	DATE 4/2/15 4/16/15 4/17/15 FSCM	PlasticsOne Medical Design and Manufacture 6591 MERRIMAN ROAD, S.W., ROANOKE, VA, 24018 PHONE: 540-772-7950 FAX: 540-989-7519
FRACTIONAL $\pm 1/64$ DECIMAL $.00 \pm .01$ [.25mm] $.000 \pm .005$ [.127mm] ANGULAR $\pm .5^\circ$		TITLE CONNECTOR, 624, 2.5MM 4 POLE RT ANGLE FLANGELESS SCALE NOTED		
SIZE B DWG 42166-50		REV A SHT 1 OF 1		

D

C

B

A