

4

3

2

1

REVISIONS			
REV	DESCRIPTION	DATE	APP'V'D
A	REL PER ECO 24113 XZ 2/19/15	3/5/15	TAB

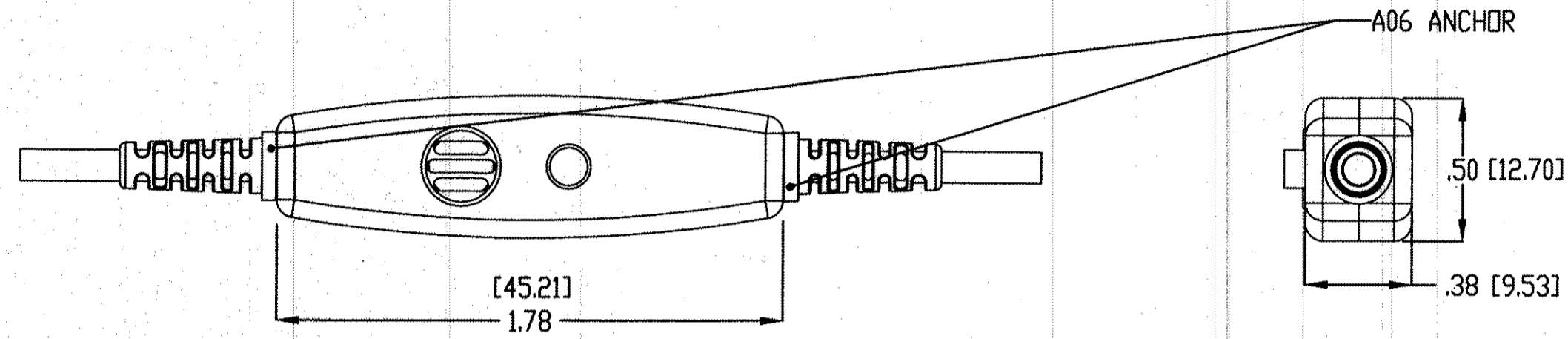

OPTION -01 J11  
(MICROPHONE)

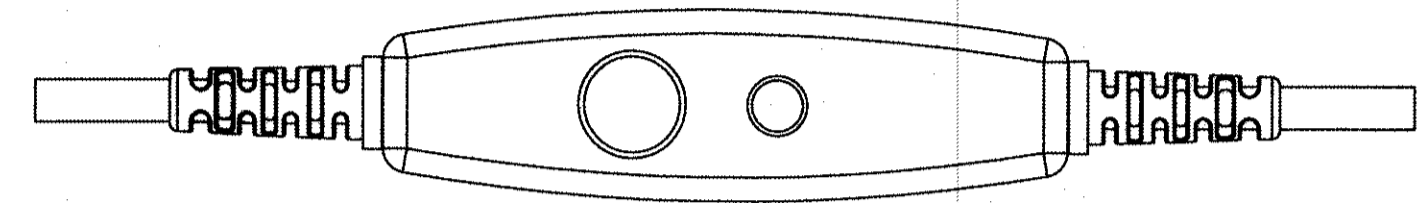

OPTION -02 J12  
(NO MICROPHONE)

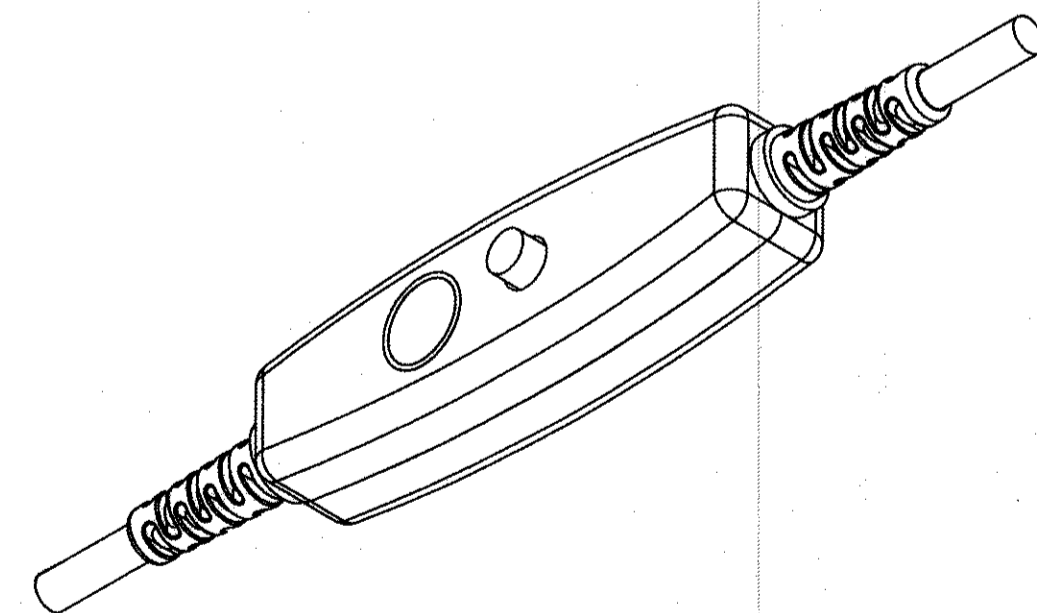
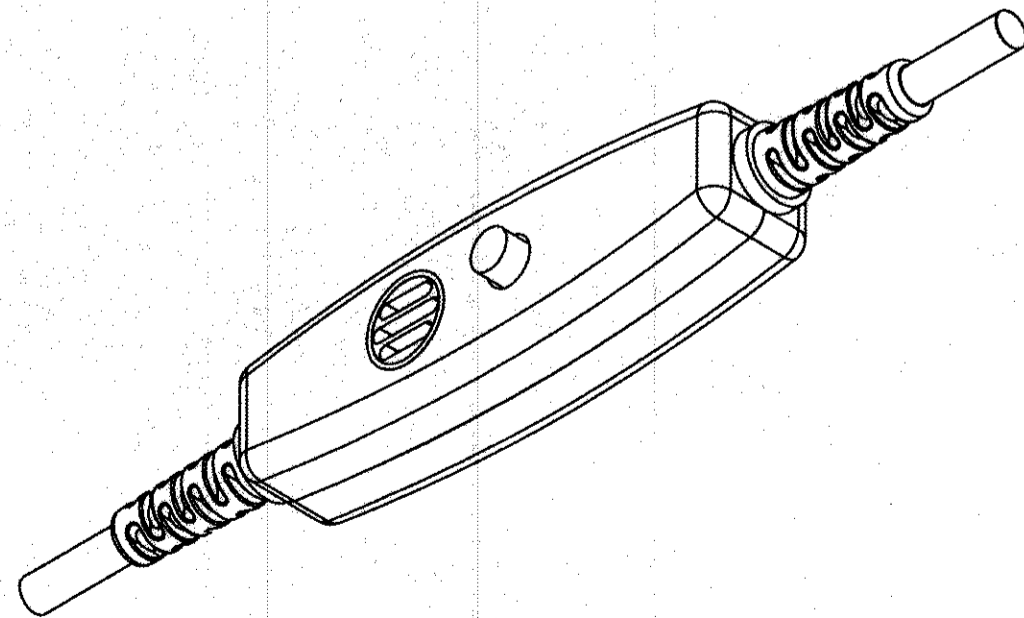
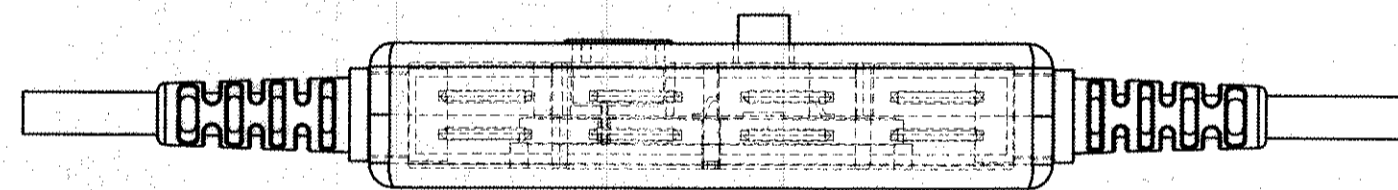

THIS DRAWING CONTAINS CONFIDENTIAL AND PROPRIETARY INFORMATION AND MAY NOT BE ISSUED OR REPRODUCED, IN WHOLE, OR IN PART, WITHOUT THE EXPRESS WRITTEN PERMISSION OF PLASTICS ONE INC.

<b>TOLERANCES</b> <small>UNLESS OTHERWISE SPECIFIED          ALL DIMENSIONS IN INCHES          DIMENSIONS IN [ ] METRIC</small>		<b>APPROVALS</b> DRAWN XZHDU CHECKED [Signature] PROJECT ENGR [Signature]	<b>DATE</b> 2/19/15 02/24/15	<b>PlasticsOne</b> Medical Design and Manufacture 6591 MERRIMAN ROAD, S.W., ROANOKE, VA, 24018 PHONE: 540-772-7950 FAX: 540-989-7519
<b>FRACTIONAL</b> ±1/64 <b>DECIMAL</b> .00 ±.01 [.25mm] .000 ±.005 [.127mm] <b>ANGULAR</b> ±.5°	<b>APPROVED</b> [Signature] PROJECT 7708	<b>DATE</b> 2/24/15	<b>TITLE</b> ASSEM., MICROPHONE/SWITCH POD, J11/J12	
<b>SCALE</b> 2/1			<b>SIZE</b> DWG C 41235-50	<b>REV</b> A <b>SHT</b> 1 <b>OF</b> 1

